

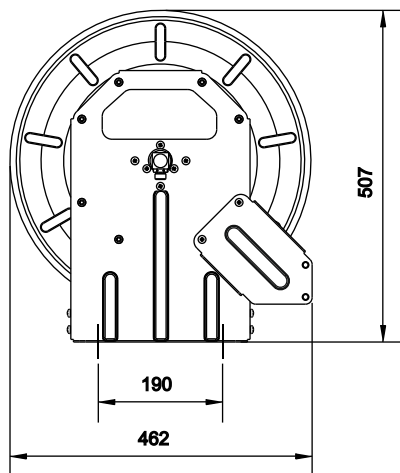

BR 7/1

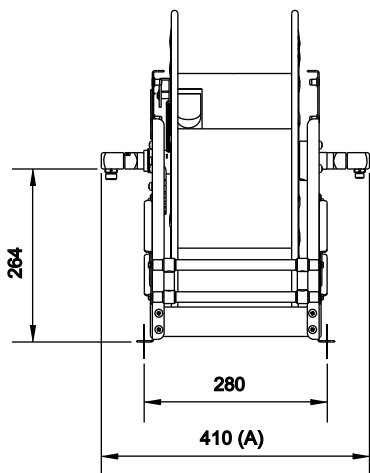

Nennweite nominal diameter diamètre nominal	Modell model modèle	Art.-Nr. ref.-no. No.-ref.	A mm	Druck bar pressure pression	Gewicht kg weight poids
6/9	7.10.6/9/1	07 001	410	max. 20	
6/9	7.15.6/9/1	07 002	410	max. 20	
6/9	7.20.6/9/1	07 003	410	max. 20	

Bauform Z1 (ATEX) ist nur in den gekennzeichneten Abmessungen lieferbar.

The Z1 (ATEX) version is only available with sizes marked.

Le type de construction Z1 (ATEX) est seule disponible en dimensions marquées.

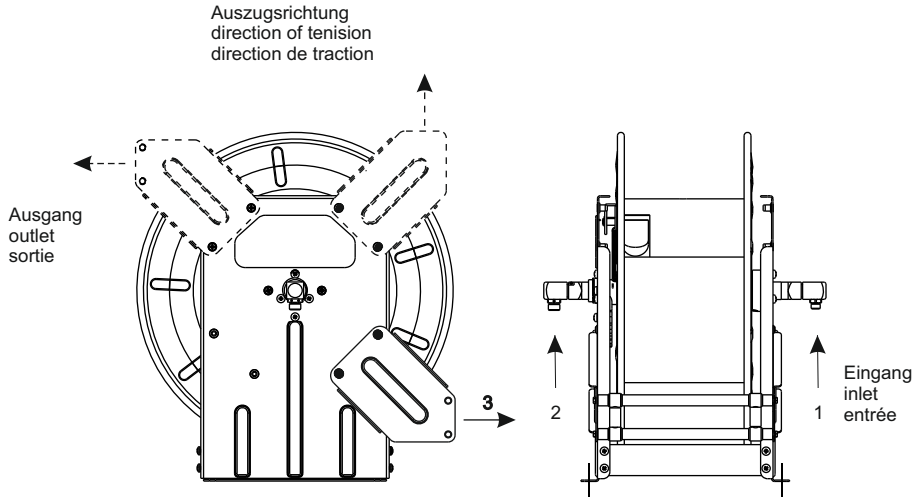

Nennweite nominal diameter diamètre nominal	Modell model modèle	Art.-Nr. ref.-no. No.-ref.	1	2	3
6/9	7.10.6/9/1	07 001	1/4"RH	3/8"LH	1/4"RH+3/8"LH
6/9	7.15.6/9/1	07 002	1/4"RH	3/8"LH	1/4"RH+3/8"LH
6/9	7.20.6/9/1	07 003	1/4"RH	3/8"LH	1/4"RH+3/8"LH

Befestigungslochbild
Ansicht von unten

holepattern
bottom view

gabarit des trous
vue d'au-dessous

